



Foam Bowl

The quality of porcelain is best reflected through its fine and delicate properties, a quality that is not celebrated when using a mould. Marcel Wanders has developed a technique to produce porcelain objects without the use of plaster moulds. A synthetic sponge is taken and dipped in a fluid porcelain clay slip. The clay impregnates the foam. Once the foam has dried, the foam is fired within a Kiln. The foam is burnt away and the perfect porcelain replica of the foam remains. An intelligent manufacturing process that has the ability to show the intricate qualities of porcelain clay.

<i>Designer</i>	Marcel Wanders
<i>Year of design</i>	1997
<i>Material</i>	Porcelain
<i>Additional Product Codes</i>	This product was developed in a project with Droog Design and Rosenthal Moooi, accessories, foambowl, MOAFO-----

Detailing



The delicate intricacy of the synthetic foam structure makes up the entirety of the bowl.

Colour



Unglazed Porcelain

m o o o i[®]

Main dimensions

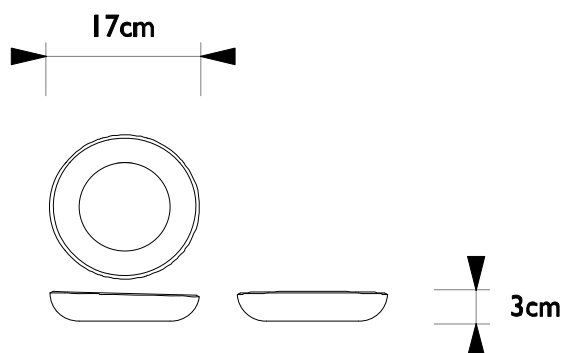

Technical

There is no technical information specific to this product.

Packaging



H-19cm
W-27cm
D-27cm



1-Colli
0.56-Net
1-Gross



The Foam bowl arrives in a gift box with no additional components.

m o o o i[®]

Photography



Photography by Kasia Gatkowska

Cleaning Instructions

To clean the Sponge vase, submerge it in lukewarm water with a little diluted washing-up liquid and allow to drip-dry in a safe place.
